



Analytical Study of Flexural and Axial Behaviour of Steel Reinforced Lightweight (Lwa) Concrete Beams and Columns Using Abaqus

G. SATHISH¹, DR.M. MURALI KRISHNA², S.D.Kumar³
Sathishsam.sam@gmail.com, kumars@srmist.edu.in

¹Pg Student, Department of Structural Engineering, SRM Institute of Science and Technology Ramapuram, Chennai

²Dean E&T,³Assistant professor Department of Structural Engineering, SRM Institute of Science and Technology Ramapuram, Chennai

Abstract: The main abstract of the paper is to increase the usage of Light Weight Concrete aggregate and More Effectively in the Structural Members. To study the Effective cross-section of steel lightweight Concrete in both the Beams and columns. By Changing the quantity of steel and LWC in Both Columns and Beam and finalizing the effective member under different loading conditions. To take advantage of current trends and technology the complete analysis will be presented by using finite element software Abaqus

Keywords: Beams, Concrete, Flexure, Lightweight, aggregates, Abaqus

1. INTRODUCTION:

The most commonly used material for construction is concrete. Important lightweight concrete is a blend consisting of a lightweight aggregate, such as shell clay, which imparts its distinctive low density. of lies cube, whereas lies between cube, light concrete is perfect for contemporary builds with the little cross-section above the base. Structural lightweight concrete (LWC) recently the use of the material

Lightweight- aggregate reduce the density of the concrete to achieve lightweight concrete The effective building of decks, girders, piers, bridges, and precast, construction, and high rise buildings Using LWC in the Wabash River Bridge, for instance, allowed builders to cut Density of the project by 17% and save 18% on costs due to lower density.



2. The Model Was Designed In The Engineering Simulation Software ABAQUES 6.14:

2.1 The Models Are Simply Supported With A Four-Point Bending, Flexural Behaviors Of Lightweight Beams Made Of Reinforced Concrete Wire Mesh Reinforced Inside By Welding. [1] Pavithra Chandramouli, Nikolai Ivanovich Vatin, Gunasekaran Murali. Results Indicate That The Ultimate Results Can Be Achieved By Increasing The Volume Of The Steel In The Concrete Instead Of Increasing The Size.

[2] *Using ABAQUS Finite Element Analysis, The Behavior Of Reinforced Concrete Beams Is Evaluated*

Hamid Sinaei, Mahdi Shariati, And Amir Hosein Abna's Concrete Damaged Plasticity Approach Is Used In The Finite Element Model, Which Can Be A Useful Addition To Laboratory Behavior Research And Serve To Validate Theoretical Predictions.

The results show a good match between the displacement, the finite element model's (FEM) tensile strain for the main reinforcement, the concrete's compressive strain, and the crack patterns.

[3] Nonlinear Elastic Isotropic Experimentally Based Model Is Used To Behavior Of Concrete Before Cracking Or Crushing. Comparison With Two Examples Of Reinforced Concrete Beams Is Studied To Show The Model's Validity. Increased And

[4] A Lightweight Concrete Shear Wall Was Studied Experimentally And Numerically. Behnoosh Rassouli, Soheil Shafaei

The Different Cross Sections Of LWC Beams Have Been Analyzed Using FEA Software – ABAQUS. Three-Point Bending And 4-Point Bending Have Been For The Beams, Similarly, The LWC Of The Column Is Also Analyzed By Various Cross-Sections. Axial Loading Has Been Carried Out For The Column Members Among These Effective Sections Has Been Finalized In Both Column And Beams

2.2 Cross-Section Of The Beams

In Beams, The Size And Number Of Bars Are Kept Constant, And The Cross-Section Of The Beam To Study The Effect Of LWC In Various Cross-Sections. The Triangular Bending Includes Four-Point Bending Examinations Carried Out For This Analysis. The Main Reinforcement 4 Nos Of 12mm Dia Bars, And 8mm Dia Stirrups Has Been Used. The Cover Of Reinforcement Rods Is 30mm. 150mm Spacing Between Stirrups Is Maintained. The Cross-Section Of Three Different Beams Is Attached Below.

2.3 Cross Section Of The Column

In The Column, The area Of The Column Is Kept Constant, And Size And Number Of Bars To Study The Effect Of Steel Proportion In The Column Section. The Axial Loading Test Is Carried



Out For This Analysis. The Cover Of Reinforcement Rods Is 40mm.150mm Spacing Between Lateral Ties Is Maintained. The Cross-Section And Reinforcement Details Of Three Different Columns Are Attached Below.

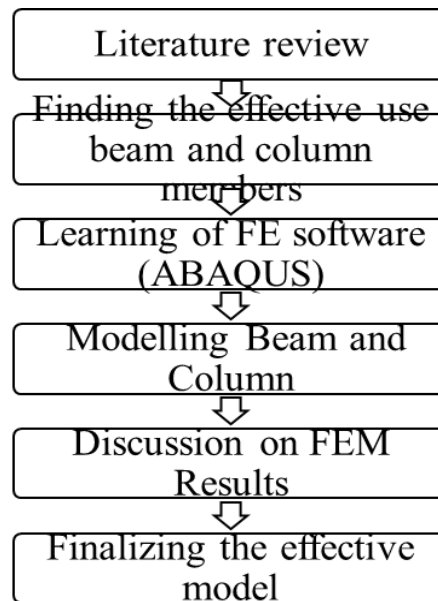

Fig. 2. Flowchart diagram for FEM

Table 1

Parametric study of the specimens						
Beam details						
S.No	Length	Breadth	Depth	Main reinforcement	Stirrups	Min cover
Specimen 1	840 mm	100 mm	120mm	10 mm dia 4 Nos	8 mm at 150mm spacing	25 mm
Specimen 2	1700 mm	100 mm	220mm	10 mm dia 4 Nos	8 mm at 150mm spacing	25 mm
Specimen 3	2500mm	100mm	320mm	10 mm dia 4 Nos	8 mm at 150mm spacing	25 mm

Abaqus Modeling Procedure

Step 1:

Based on these inputs, the model has been generated in the ABAQUS.

Step 2:

The property of steel and concrete has been assigned to the respective members



Step 3:

The steel and concrete elements are assembled based on the below arrangements.

Step 4:

Two points at the bottom of the beam is fixed by using the option ENCASTRE in Load tab .These two points are 20mm away from the edge. The 2 loading applied in on the top face of the beam element. The loads are applied at 220mm from the edge of the beam. Refer above image for the loading details

Step5:

The bonding between steel and concrete is applied in the interaction. For this application, the Embedded region is applied.

Step6: To find more accuracy of the results, the size of the mesh is 10mm for all the components. Refer Above image for meshing details.

Results

Mesh detail

2 PICTORIAL REPRESENTATION:

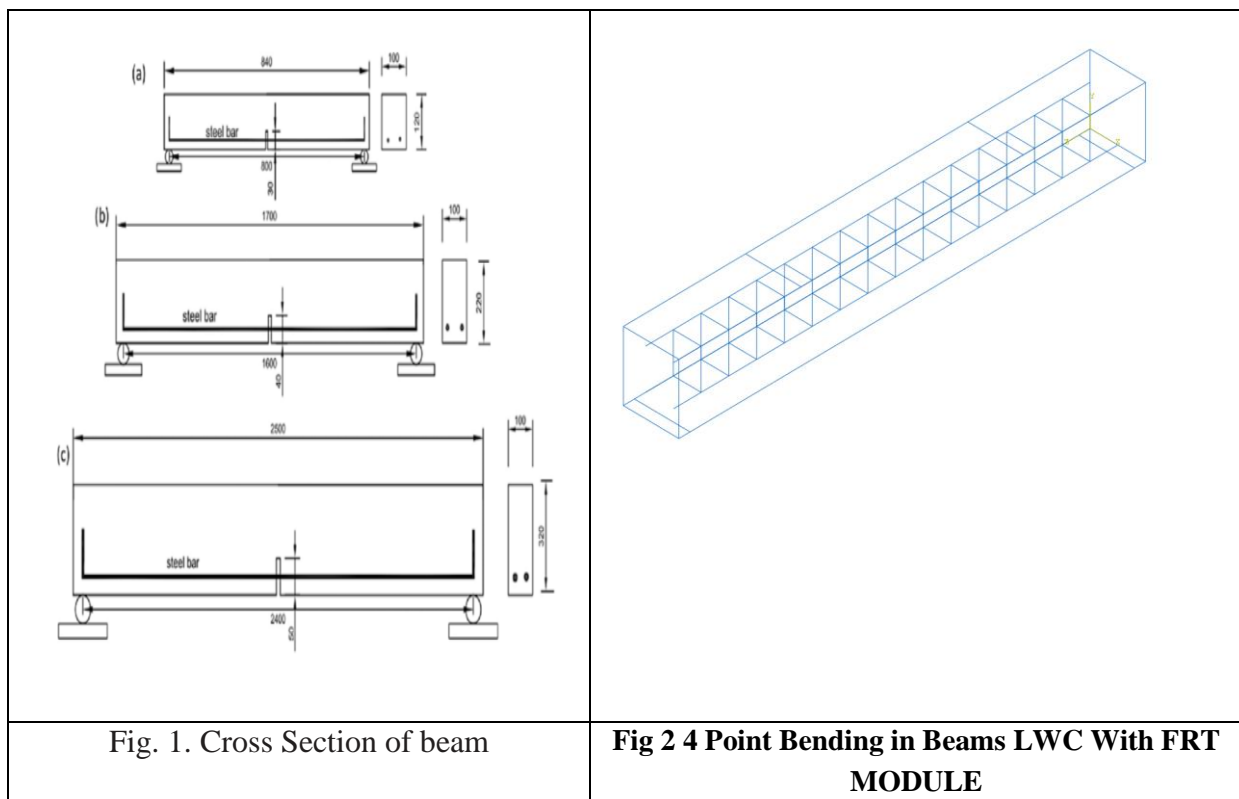

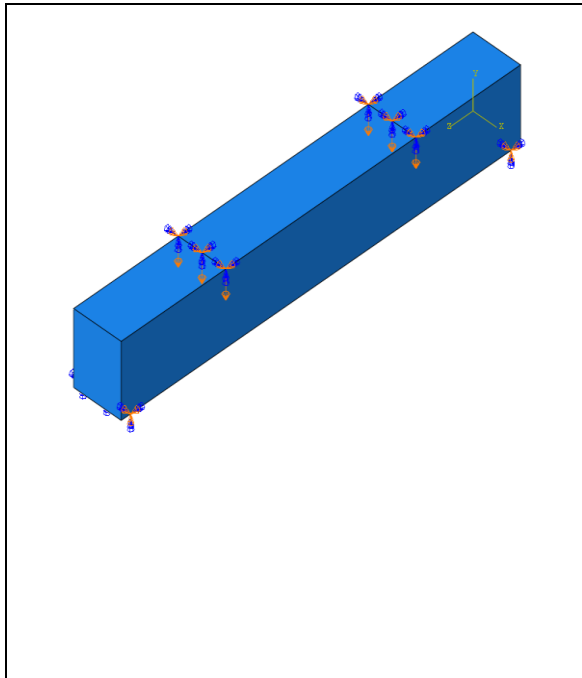

Fig 3 LOADING DETAIL Specimen 1

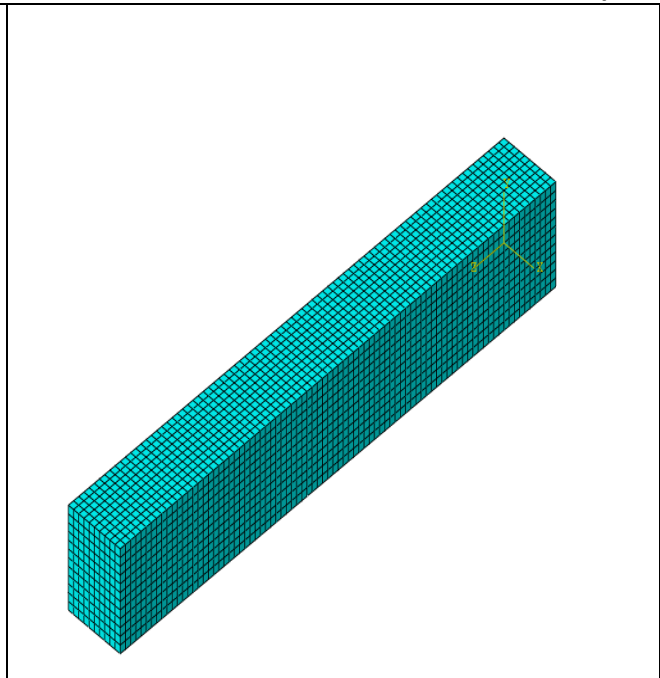

Fig.4.Mesh details

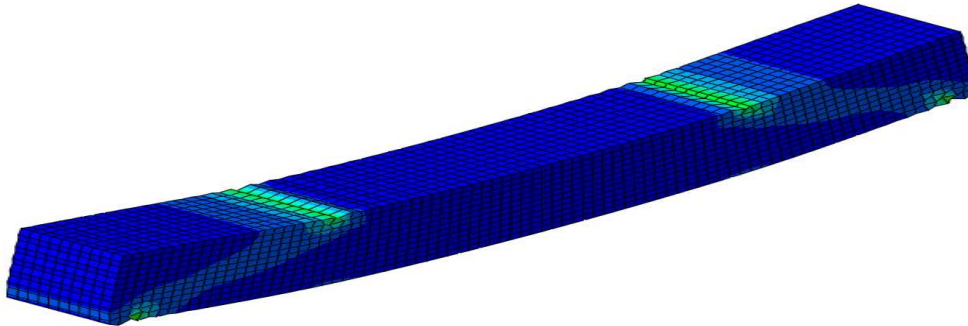

Fig 5

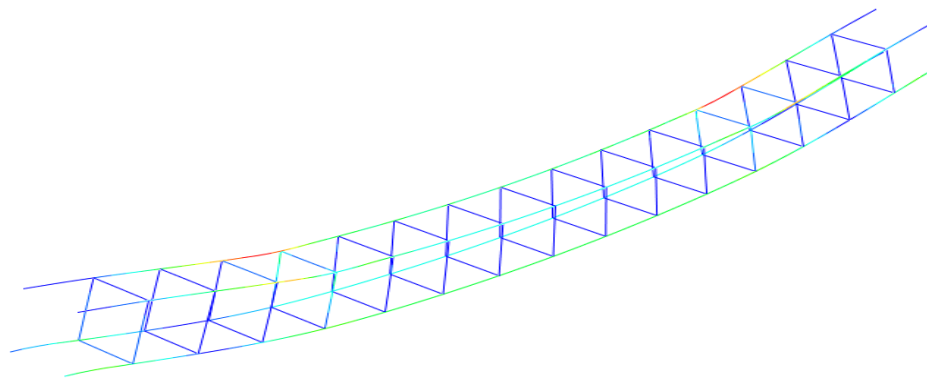

Fig 6 Deformation of Reinforcement

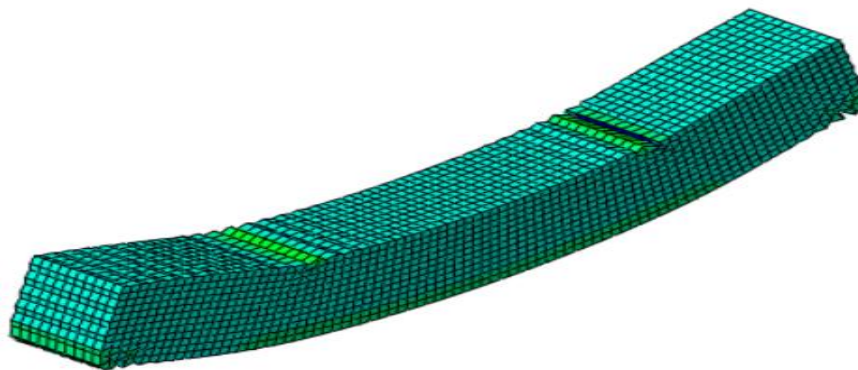

Fig.7: Max Principle

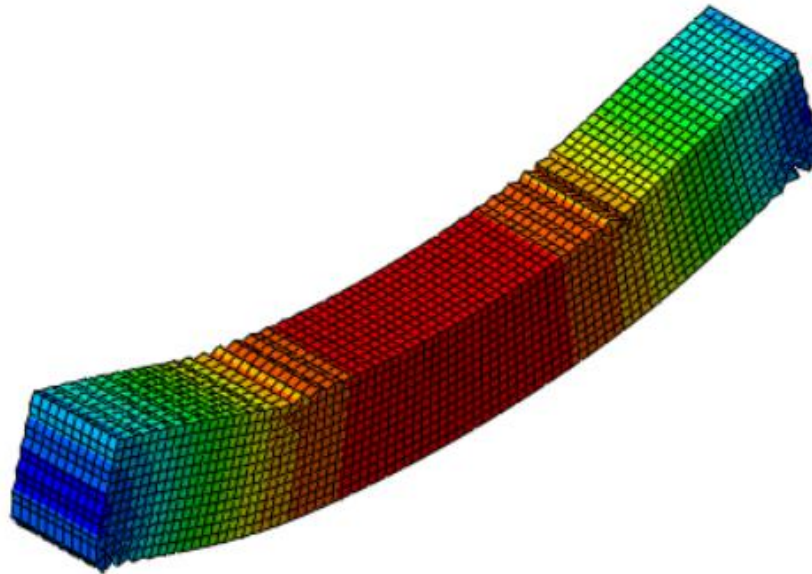

Fig 8. Maximum deflection on U1

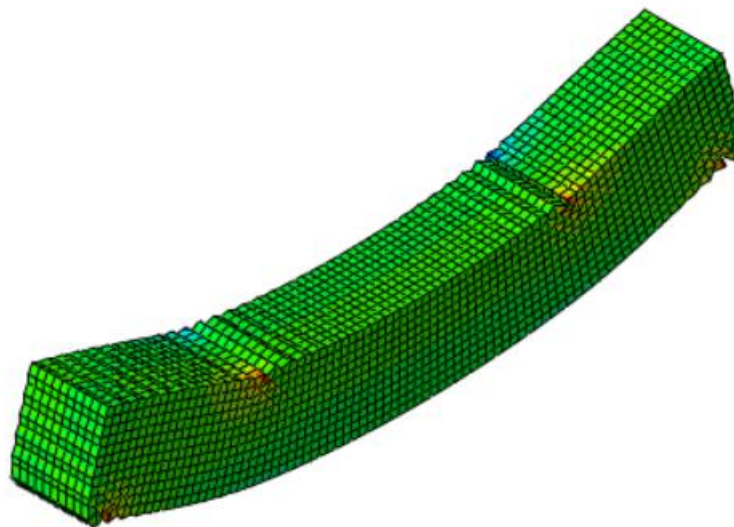

Fig 9. Maximum deflection on U2

3. I- section as reinforcement

ISMB250 section has been used for the analysis. The modelled section has shown in the below figure. To replace the steel reinforcement, I section has been check the load carrying capacity of the element. The load vs deflection table has been listed below.

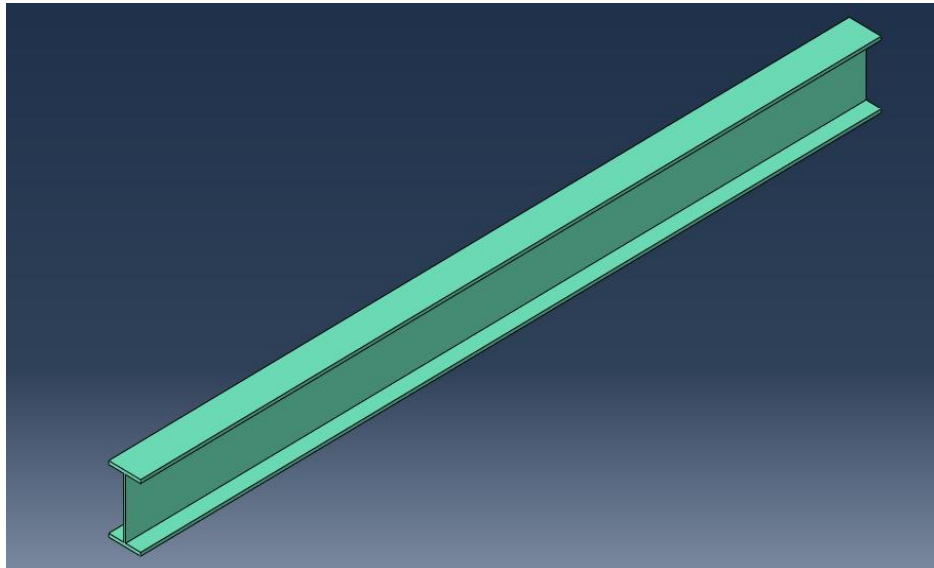

Fig 10. Modelling of I-Section in ABAQUS

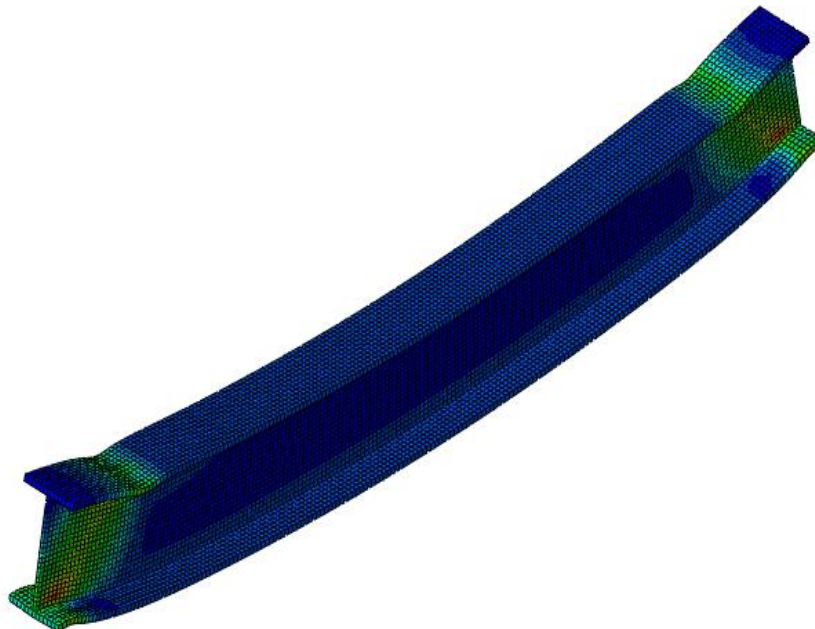

Fig 11. Deformation of reinforcement at maximum load



3.1 Rectangular hollow section as reinforcement

Rectangular hollow section has been used for the analysis. The modelled section has shown in the below figure. To replace the steel reinforcement, this section has been used to check the load carrying capacity of the element. The load vs deflection table has been listed below.

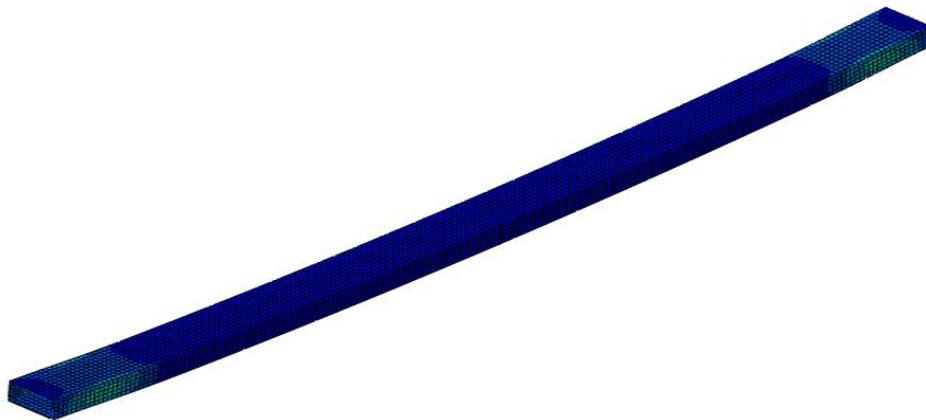

Fig 12. Deformation of rectangular section at maximum load

1. Circular hollow section as reinforcement

Circular hollow section has been used for the analysis. The modelled section has shown in the below figure. To replace the steel reinforcement, this section has been used to check the load-bearing capability of the element. The load vs deflection table has been listed below.

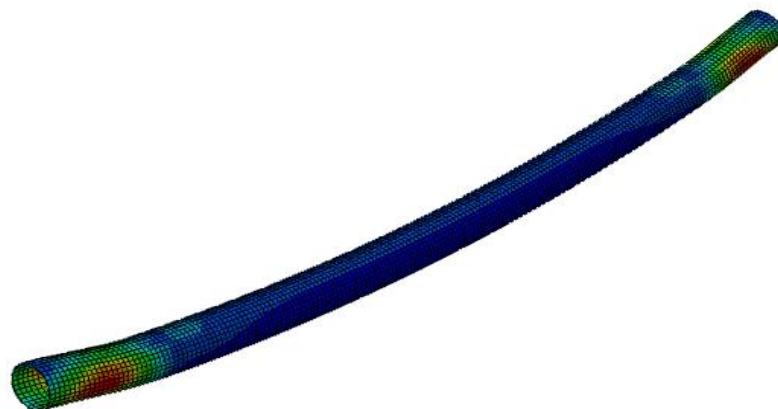
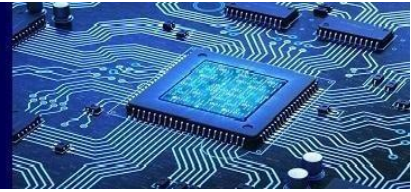

Fig 12 Circular Hollow Section



The analysis of the column is done by assigning the properties to the model. It indicates the error free model when the analysis runs without aborting. The analysis results are viewed in the Visualization module.

4.2 AXIAL LOAD IN COLUMN.

The cross section of the column kept constant and changing the reinforcement in this section. The results are listed below. The results of specimen 1 are listed below. The cross section of beam detailed in Chapter 6.



Fig 13. Maximum stress in column



Fig 14. Minimum principle in column



Fig 15. Maximum stress in reinforcement of the column

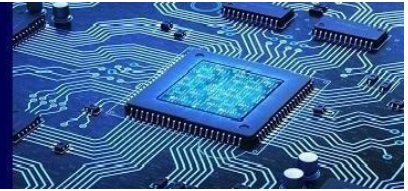

Fig.9. Sample certificate

• **CONCLUSION:**

Based on the above graphs, the maximum quantity of steel used in specimen with reinforcement, but it provides less load carrying capacity. Whereas the other specimen like I-Beam, Rectangular hollow and Circular hollow are high and less in steel quantity.

To use the quantity of steel in a effective way instead of reinforcement, composite can be followed. The member with circular and rectangular hollow section are quite similar in both quantity and load carrying capacity. Among the composite beams, the I-section gives the maximum load carrying capacity, but the steel used for i-section is quite higher than the rectangular and circular hollow sections. Hence, the specimen with lesser steel quantity and provides more load carrying capacity are rectangular and circular section. This paper illustrates the effective steel section of the beam.



References:

- Aydin Demir, Hakan Ozturk, Gokhan Dok, (2016) 3D Numerical Modeling Of RC Deep Beam Behavior By Nonlinear Finite Element Analysis.
- Pavithra Chandramouli, Nikolaiivanovich Vatin, Gunasekaran Murali (2022) Flexural Behaviour Of Lightweight Reinforced Concrete Beams Internally Reinforced With Welded Wire Mesh
- R. E. Philleo (1973) A Numerical Approach To The Complete Stress-Strain Curve of Concrete.
- Xiaoluo Cao, Linmei Wu, Zhenming Li (2019) Behaviour Of Steel-Reinforced Concrete Columns Under Combined Torsion Based On ABAQUS FEA.
- Hamid Sinaei, Mahdi Shariati, Amir Hosein Abna (2012) Evaluation Of Reinforced Concrete Beam Behaviour Using Finite Element Analysis By ABAQUS
- Touhami Tahenni, Farid Bouziadi, Bensaid Boulekbache (2021) Experimental and Nonlinear Finite Element Analysis Of Shear Behaviour Of Reinforced Concrete Beams.
- Fariborz Barzegar, Associate Member, ASCE, And Srinivas Maddipudi (1993) Generating Reinforcement In Fe Modeling Of Concrete Structures.