



## State of the Art Paper on Optimization of Pre-Engineered Buildings

P. Santhoshisri<sup>1</sup>, Dr. M.Saravanan<sup>2</sup>, Dr. Padmaja Gokaraju<sup>3</sup>,

1. MTech Student at MLRTM  
College, Hyderabad, Telangana.

2. Assistant Professor, Department of Civil  
Engineering, MLRTM, Hyderabad,  
Telangana.

3. Vice President-Designs at M/s Kirby  
Building Systems & Structures India Pvt. Ltd.,  
Hyderabad.

[Santhoshisri611@gmail.com](mailto:Santhoshisri611@gmail.com)

**Abstract:** The main idea of this paper is to explore about the major purpose of pre-engineered buildings in view of steel consumption factor, compared to conventional steel buildings. Past studies proved that Pre-engineered buildings are well suitable for various industrial applications with economical solutions. Review of literature on optimal bay spacing of Pre-engineered buildings is carried out in self-structures. This helped to identify a research methodology to work on optimal bay spacing of a pre-engineered building with variable parameters like, span, frame type, bay spacing, height, roof slope, wind loads etc.,

**Keywords:** Pre-engineered buildings, Conventional buildings, steel consumption factor and optimization of economical bay spacing.

### 1. INTRODUCTION:

The term "Pre-Engineered Building" is commonly referred to as PEB. It encompasses primary members, secondary members, and a roof system that includes accessories derived from the structural components of a pre-engineered building. PEBs are a preferred choice for sustainable and eco-friendly construction due to the fact that steel is 100% recyclable and can be repurposed for the creation of other products. PEBs utilize simple nut and bolt connections for the installation of sections, which are manufactured in the factory according to the customer's specifications and assembled following standard procedures. PEBs are lightweight, allowing for quicker design, detailing, and factory fabrication with quality control. They also offer faster completion, single source responsibility, ease of future expansion, larger clear spans of up to 100 meters, earthquake resistance, energy efficiency, and more, thereby accelerating the construction process. Pre-engineered buildings find common applications in warehouses, industrial facilities, commercial buildings, agricultural structures, aircraft hangars, and sports facilities. Overall, pre-engineered buildings provide a versatile, cost-effective, and efficient solution for various construction projects [1].

The optimization of pre-engineered buildings relies heavily on the consideration of tapered sections in the building's frame. By incorporating large tapered sections to bear higher loads, designers are able to create the most efficient design for the structure, resulting in optimal steel consumption and economic efficiency. Additionally, the use of cold frame sections, which are designed to withstand lateral buckling and torsional forces, allows for thinner

sections over larger spans. These sections overlap to form a continuous beam, increasing the load carrying capacity while minimizing the usage of steel, thus making the building more cost-effective. The use of High-tensile steel in pre-engineered buildings is due to its ability to bear heavy weights and withstand harsh weather conditions. By optimizing the width and thickness of frame elements, designers can minimize steel consumption by considering bending moments and load factors. In pre-engineered buildings, the member frame is treated as a continuous beam, resulting in lower moments and reactions and a higher structural unity compared to conventional buildings, where members are assumed to be simply supported and experience higher moments and reactions.

## **2. OBJECTIVES:**

The primary objective of optimization in pre-engineered buildings is to enhancing efficiency and cost effectiveness in the construction .The efficiency of structure can be obtained by the optimization of structure using the economical bay spacing in PEB that are derived by empirical formulae which are viewed from literature review for the best evaluate of economy structure for large span with varying parameter that are considered as the major source for design of PEB structure which are result in best performance that view to the cost effectiveness in construction due to the steel take off reduction. As the steel is major part source of material which is used in PEB structure. So, the usage of steel less in structure result the cost reduction of construction for effectiveness. This viewed to further study on the optimization of pre-engineered building for economical bay spacing with RF-frame of large span and varying parameter with consider of standard codes and values that helps to reduction in cost of construction with view of steel take-off factor that are viewed.

## **3. REVIEW OF LITERATURES:**

By summaries of previous literature review that comparison of conventional building to pre-engineering buildings the steel take off is more economical [2]. By adjusting the bay spacing and roof angle, the PEB structure can be optimized for steel consumption [3]. By consideration of standard value like design, loads, steel Take Off, foundation reaction, delivery material, erection, and cost, change of order, future expansion and performance is more optimize for PEB [4]. Similar review is carried out with number of possibility comparison between them [5]. All this study reviews the comparison of conventional building to pre-engineered building are more economical up to (25-30%) of steel take off for optimization. By adjusting various parameter like ridge angles, bay spacing, span varying, grade of steel, making constant height of building for optimized the steel consumption in PEB's[6].This study review the optimization of PEB's on different strata by steel consumption with different parameter consideration[7].By adjusting the parameter of bay spacing, span length and width with standard values consideration of making height constant in optimization of PEB's and derived the empirical formula which result to find the economical bay spacing[8]. By study of design and analysis over an secondary member by comparison PEB's are most economical structure by using software for easy output [9 & 10].These studies says that optimization of PEB's needed to be continued for further observation & study over a RF-Frame in PEB's with consider of various typical parameter and standard values that result to optimal bay spacing values and steel take off consumption to the less which leads to cost reduction of structure.

## **4. CONCEPT OF “PRE-ENGINEERED BUILDING”:**

A typical assembly of steel structure elements as a form of a building member system as known in figure: 1 with descried of various building components as below:

- Primary members,
- Secondary members and
- Accessories.

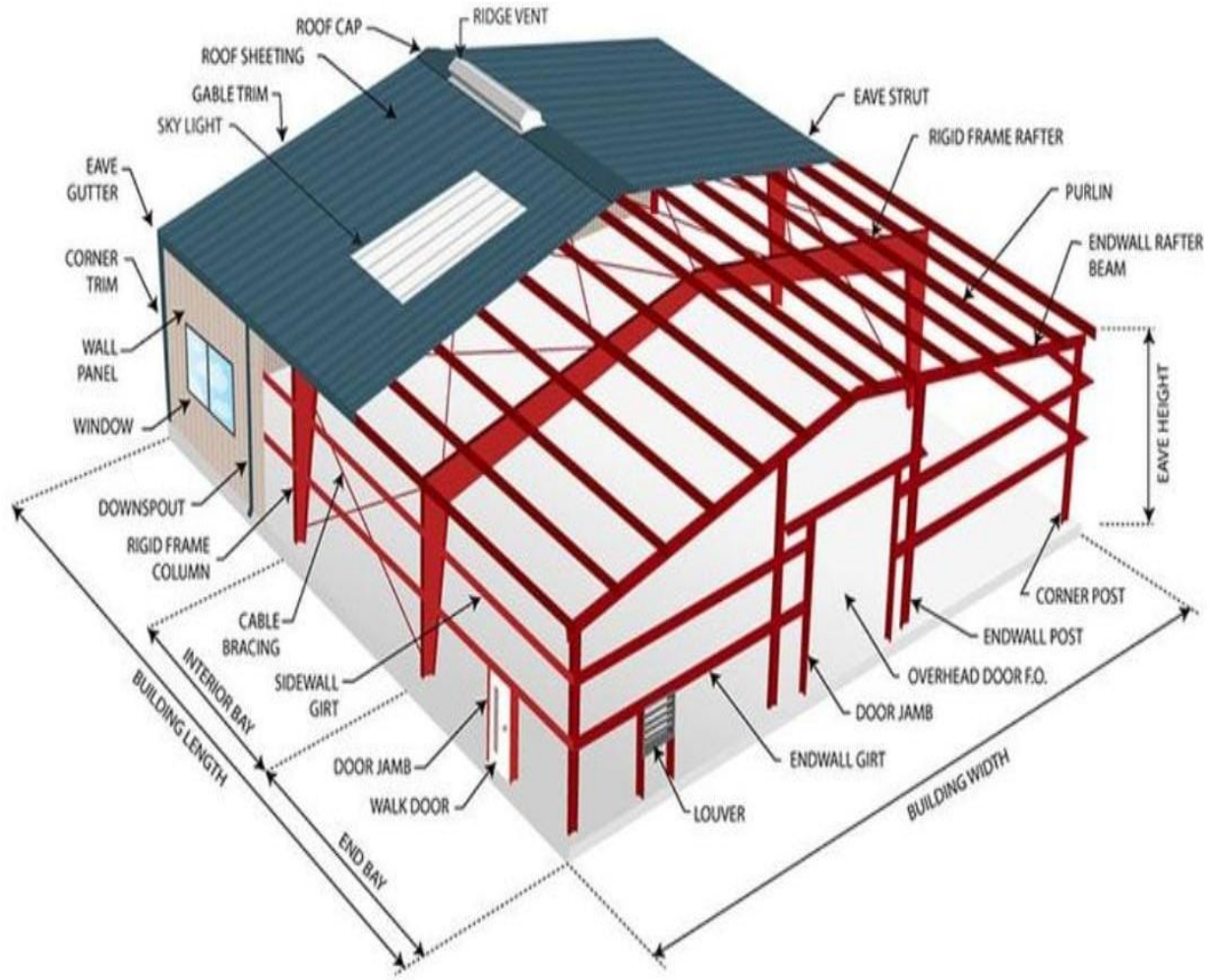

Figure: 01 - Typical arrangements of Pre-Engineered Building.

#### 4.1. Primary Members:

Primary structural framing shall refer to the transverse rigid frames, lean-to rafters & columns canopy rafters, interior columns (beams and column frames), bearing frame rafters and corners columns and end wall wind columns. For the selected primary framing, high strength Gr 50 of yield strength 345MPa plates are used to form 3 plated built up I sections. To use steel optimally where required, built-up tapered beam sections are considered for columns and rafters as per the design. These are different primary framing system shown in below figures: 2 and 3.

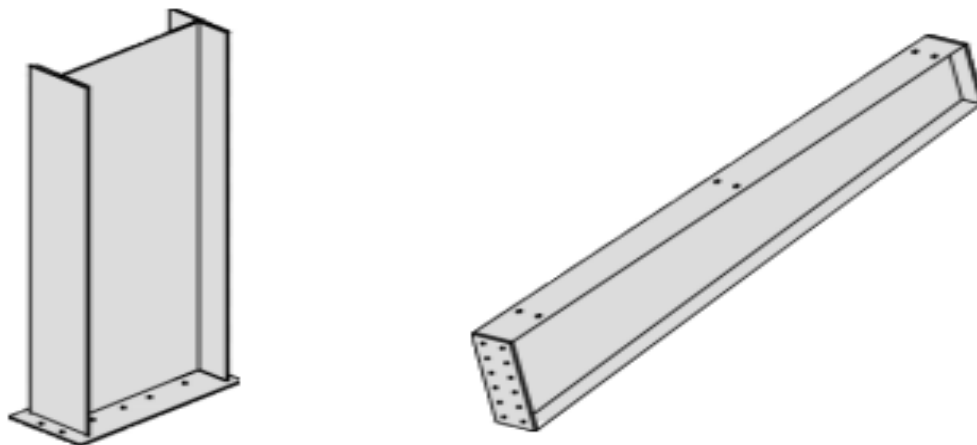

Figure: 02 - Illustrates structural supporting elements consists of columns and rafter.



Figure: 03 - Primary framing structure.

#### 4.2. Secondary Members:

Secondary structural framing shall refer to purlins, girts, eave struts, wind bracing, flange bracing, base angles, clips & other miscellaneous structural parts. Girts and purlins form the secondary components which are used as a support system for walls and panels of roofs. The purlins are used on roofs and girts are used on walls. The main function of the secondary members is that it acts as struts which help in counter acting the part of loads which act on the building like wind and seismic loads and they provide lateral-bracings to the flanges in compression of the members of the main frame thereby increasing the capacity of the frame. Conforming to ASTM A653, Cold rolled High strength  $F_y$  345 MPa black/hot dipped galvanized carbon steel is available in coils and sheets depending on thickness. (0.6mm to 3.15mmThk). Phosphate treatment and chromate free sealing is adopted in COLD ROLLING to make the product environmentally friendly. Based on application and corrosion protection required, galvanization thickness can be varied from 30 gsm to 600 gsm. Coils are available with required corrosion resistance, outstanding appearance, workability, paint ability, and weldability. In PEB, all secondary members are of cold formed Zee and Cee sections, shown in Figure: 4. These sections are used to support roof sheeting and wall cladding and are placed underneath them. Uniform section depth is adopted for full length of the building to achieve continuous beam concept through lapping.

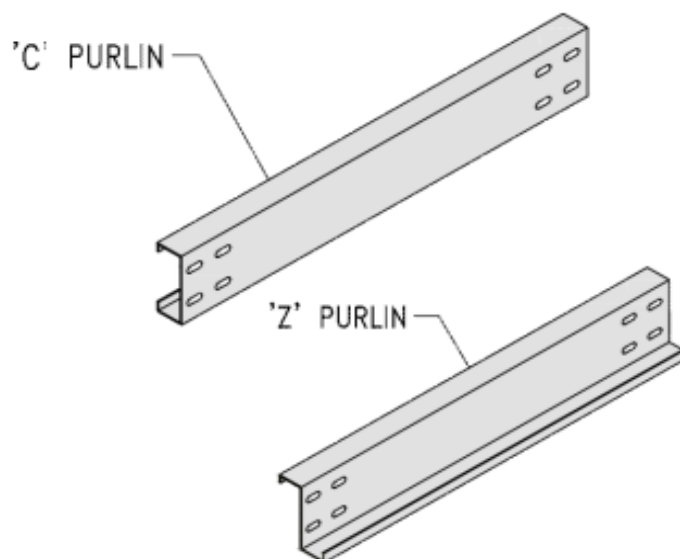

Figure: 04 – Different types of secondary members ('C-Purlin' and 'Z-Purlin').

#### 4.3. Connections:

- All field connections shall be bolted (Unless otherwise noted).
- Primary bolted connections shall be furnished with high strength bolts conforming to the physical specifications of ASTM A325 (or equivalent).
- Secondary bolted connections shall be furnished with machine bolts conform to the physical specifications of ASTM A307 (or equivalent).

#### 4.4. Roof and Wall Sheeting:

Typical roof, wall & liner panels shall be color coated, 26 gauge, galvalume or galvanized coated steel, ribbed panels. (Other material & thickness available upon requirement). The sheets which are used for the construction of steel structures consist of a base metal made up of either galvanized or galvalume substrate steel panels of 345mpa with specification of ASTM A-653 or A-792 M grade. If it is zinc coating and a hot dip galvanization process conforming to ASTM specification A653 with a coating class of G-90 or with galvalume coating to ASTM A-792-AZ150 or equivalent as shown in Figure: 5.

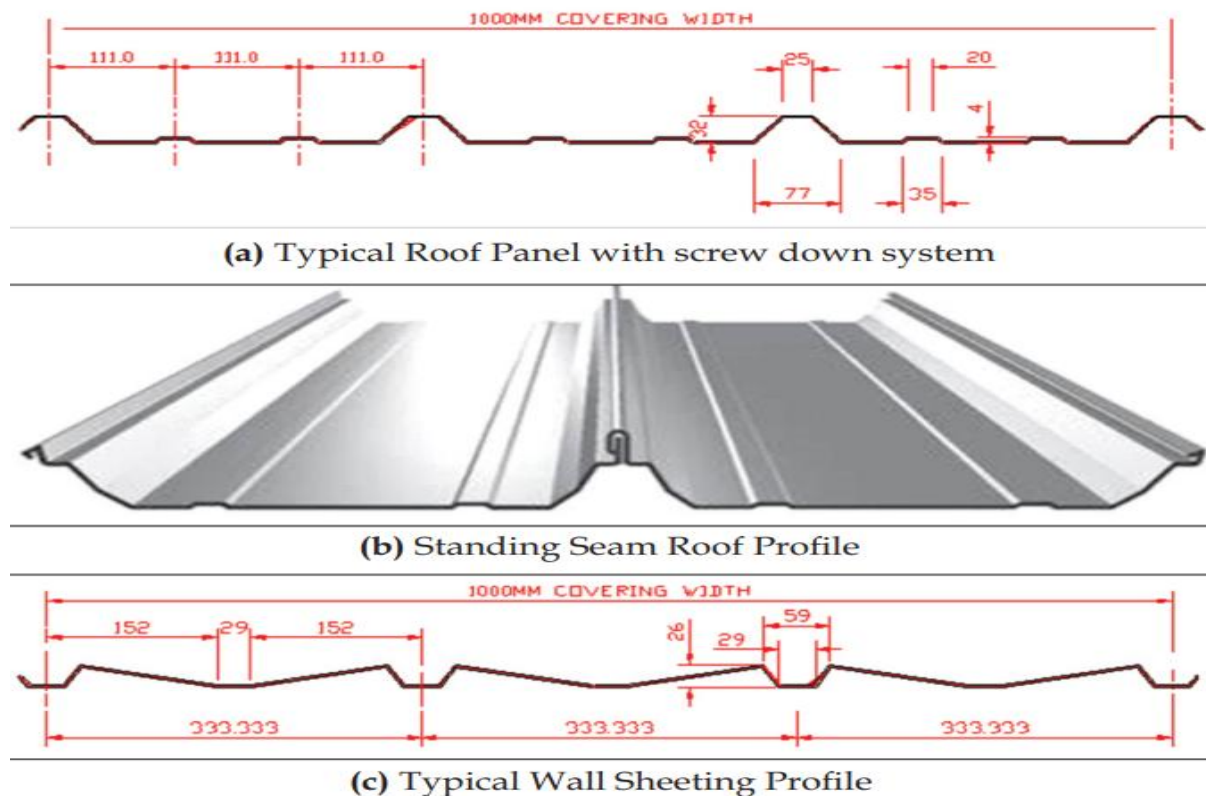

Figure: 05 – The Typical roof sheeting and wall sheeting.

#### 4.5. Fasteners, Sealers, Flashing, Trim & Closures:

- Fasteners should have self-drilling sheet metal screws with metal & EPDM washers, which conform to American standards association specifications. All screws shall have hex heads.
- Sealers for Side laps, End laps & self-flashing windows shall be 6x5mm thick, composed of synthetic rubbers, plasticizers & inert fillers. The sealer shall be non-asphaltic, non-shrinking, on drying & non-toxic & shall have superior adhesion to metals, plastics & painted surface.
- Flashing, Trim & Closures shall be furnished at the Rake, Corners, Eaves, framed openings & wherever necessary to provide weather tightness & finished appearance.

#### 4.6. Accessories:

All frames and structural members are united by using the accessories such as Anchor bolt,

standard personal doors, Sliding doors, Roll-up doors, Windows, Sky-light, Eave gutters, Downspouts, Ventilators, Louvers, Puff panels & Insulations along with Roof curbs and Roof jack. Below are the sums of figures of accessories of Pre-engineered building.

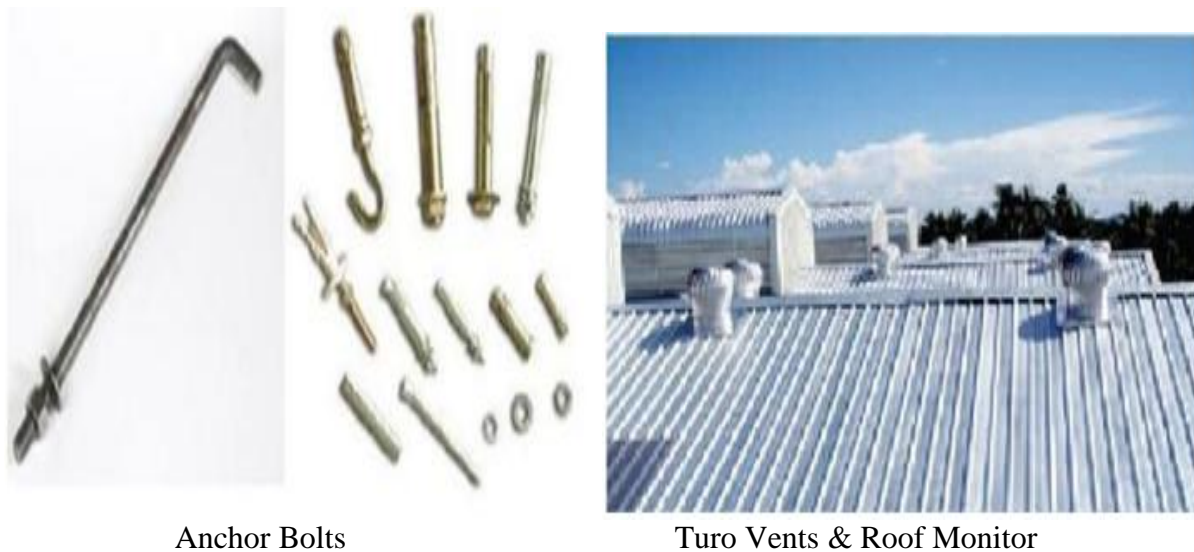

Anchor Bolts

Turo Vents & Roof Monitor

Figure: 06 – Anchor bolts and Roof monitor with Turo vents.

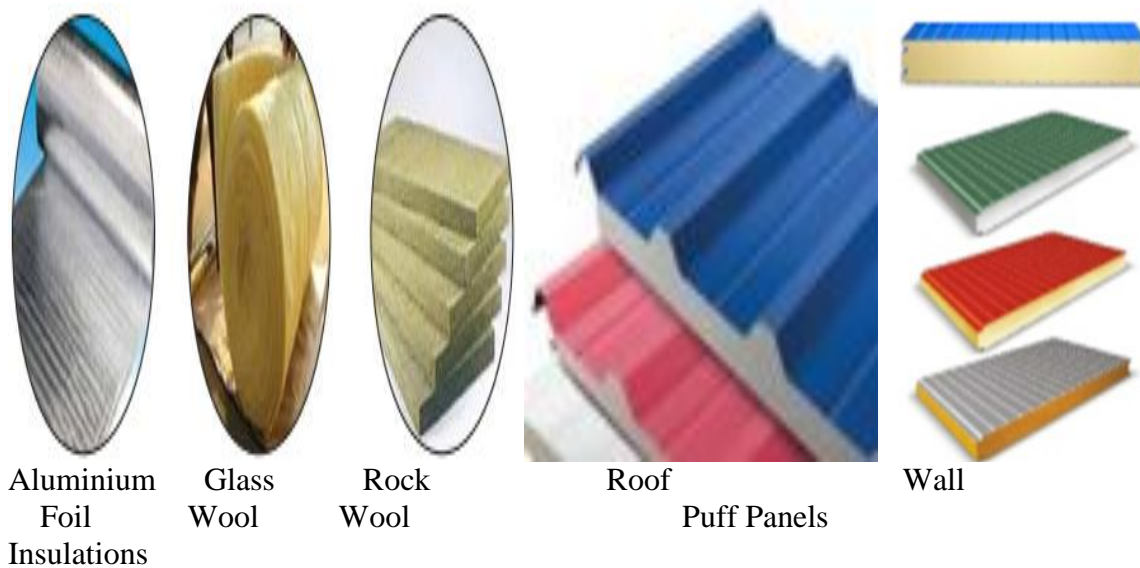

Aluminium  
Foil  
Insulations

Glass  
Wool

Rock  
Wool

Roof  
Puff Panels

Wall

Figure: 6.1 – The various categories of insulation and puff panels used for roofs and walls.



### 5. CASE STUDIES:

This case study showcases that based on the application and usage the selection of typical frame of structure is taken for pre-engineered building which helps to the design and easy to achieve an economical structure and contribute to the rapid development of PEB construction.

### 6. CONCLUSIONS:

Based on previous reviews, it has been demonstrated that Pre-Engineered buildings can reduce steel weights by 25-35% in comparison to traditional buildings. While there has been some research on PEB with restricted structural parameters, it is clear that additional investigation is necessary to explore various aspects such as building dimensions, frame types, roof slopes, heights, wind loads, etc., in order to provide comprehensive guidance to users. Therefore, further examination of rigid frame type frames with different parameters to further research.

### 7. References:

- [1] Alexander Newman “Metal buildings system” Textbook Copyright © 1997, 2004,2015 by McGraw-Hill Education. ISBN: 978-0-07-182897-0.
- [2] Gokul P.T. et al, “An Optimization of Pre-Engineered Building- A Review”,IJRPR, Vol 4, no 12, pp 507-509 December 2023. Journal homepage: [www.ijrpr.com](http://www.ijrpr.com) ISSN 2582-7421
- [3] Advait Sagavekar et al, “Optimization of Pre-Engineered Building Structures”,(IRJET), Volume: 08 Issue: 01. e-ISSN: 2395-0056; p-ISSN: 2395-0072;[www.irjet.net](http://www.irjet.net).
- [4] C. M. Meera, “Pre-engineered Building Design of an Industrial Warehouse”.(IJESET), ISSN: 2231 – 6604, Volume: 05, Issue 2, pp: 75-82.
- [5] Kavya.Rao.M. et al, “Design Optimisation of an Industrial Structure from Steel Frame to Pre-Engineered Building”, (IJRAT), E-ISSN: 2321-9637, Volume: 02, No.9.
- [6] B K Raghu Prasad et al, “Optimization of Pre-Engineered Buildings”.(IJERA),ISSN : 2248-9622, Volume: 04, Issue 9( Version 6),pp.174-183.
- [7] V. P. Raut et al, “Design Optimisation of an Industrial Structure from Steel Frame to Pre-Engineered Building”,(Journal NX)- A Multidisciplinary Peer Reviewed Journal (ISSN No:2581-4230).
- [8] Dr. Padmaja Gokaraju et al, “A Study on Optimal spacing Of Low-Rise Metal Buildings”, Jawaharlal Nehru Technological University Hyderabad, MTech project review.
- [9] P.S.L. Hima Bindu et al, “Weight Comparision Of Industrial Buildings: Peb Vs Conventional”,Vignana Jyothi Institute Of Engineering And Technology,B.Tech Project review.
- [10] A.Deepti et al , “Study Of Industrial Buildings (Peb Vs Conventional) And Developing A Software For The Design Of Purlin Sections Using Microsoft Excel”. Vignana Jyothi Institute Of Engineering And Technology,B.Tech Project review.

Ms.P. Santhoshisri<sup>1</sup>, Dr. M.Saravanan<sup>2</sup>, Dr. Padmaja Gokaraju<sup>3</sup>