



AUTO CONTROL OF VEHICLE ENGINE AT TRAFFIC SIGNALING POST

Dr.Syed Jahangir Badashah¹,Dr.S N Chandra
Shekar²,V.Niharika³,CH.Rahul⁴,B.Anoop⁵

¹Associate Professor ² Assistant Professor, Sreenidhi Institute of Science of
Technology ,Ghatkesar-501301,Telangana,India0

^{3,4,5}UG Student, Sreenidhi Institute of Science of Technology ,Ghatkesar-
501301,Telangana,India

ABSTRACT

The project designed here is an automatic vehicle control as per the traffic signaling system. The main aim of this project work is to save the fuel of the vehicle and reducing the pollution. The demo module is designed with a proto type vehicle in a single direction of the traffic signaling post. As this is of single direction, the traffic signal post is designed with one RED and one GREEN indicator. The traffic signaling post communicates with the vehicle through wireless network Zigbee technology. So the signal post acts as transmitting section and the vehicle will be receiving section. The transmitting section at the traffic signal post is designed with microcontroller, indicators, Zigbee transmitter and an IR sensing circuit for detecting the vehicle entered into the zone. And the receiving section i.e., vehicle is designed with micro controller, Zigbee receiver, start and stop buttons, LCD for displaying the time left to change the signal to GREEN, alarm, relays and DC motors for the vehicle movement. Total 3 DC motors are used for the vehicle in which two are used for the vehicle movement and one motor is used to indicate the vehicle engine ON or OFF state. Once the vehicle enters in to the signal post zone which is detected by the IR sensor arranged before the signal post, the controller in the transmitting section transmits the time duration of the RED signal to the vehicle. If the time duration is more than 10 seconds, the controller in the vehicle activates the alarm to switch OFF the engine. If the engine is not switched OFF, the controller automatically OFF's the engine. If the time duration is less than 10 seconds, the vehicle's engine will not be switched OFF. By this type of system, lot of fuel can be saved and the pollution can also be decreased. This way the traffic signaling system can be designed to other three directions as well.[1]

1. INTRODUCTION

Congestion is becoming a major issue in several major cities globally. The situation is more complicated in emerging nations due to the rapid urbanization compared to industrialized nations. In contrast to the 0.7% yearly growth rate in industrialized nations, emerging nations are believed to see population growth of roughly 5% on average. The traffic is becoming worse every day as a result of the growing population. Nowadays, going out during peak hours, especially in major cities, is an absolute nightmare. Finding a location close to a lot of intersections with traffic signals takes hours. Since the number of road vehicles and passengers is increasing at a rapid pace, automotive technologies are becoming more integrated into current road traffic-control systems. The field of traffic engineering conducts both static and dynamic analyses, as well as syntheses, in order to meet the ever-present need for safety-critical traffic automation.

potential technologies for automobiles. Planning and managing traffic networks and designing intelligent autos with artificial intelligence (AI) so they can make judgments on their own is engineering's primary focus. Optimal and dependable control structures for urban traffic and highway systems are being developed as part of this project. To reduce fuel consumption at the signal post, it is necessary to have an intelligent and cooperative setup of the actuators and how they are linked to the control system in the center. It is also possible to lessen the negative effects on the environment, such as pollution. Transportation delays are becoming more common as a result of both the rising volume of road users and the constraints imposed by existing infrastructures. Traffic light controllers have a significant impact on city traffic. The motorist wastes time and gas while sitting at a traffic signal. Using increasingly complex algorithms for traffic light management and the proliferation of new technologies like communication and sensor networks, we can make car controllers smarter.

intelligent traffic signal regulation, drivers not only have their wait times reduced, but they also get tips on how to navigate a city more efficiently, which in turn reduces pollution and fuel consumption. This implies that we are dealing with a multi-agent system that is complicated and requires coordination and communication.[2] Our study's innovative approach optimizes traffic signal controllers and drivers' actions with the use of machine learning. In most cases, when drivers approach the traffic signaling post and see a RED light, they will come to a complete stop. However, it is human nature for car engines to remain on. More pollution is produced as a result of gasoline burning occurring even while the vehicle is not in motion. In order to lessen environmental damage and automobile fuel use, this concept proposes an automated alternative. The abstract states that the signal post transmits the time length to change the RED signal to GREEN. After receiving the signal, the car shows the current time on the LCD. When the time exceeds the program's preset setting, the controller will automatically turn off the engine. Infrared sensors for approaching the road at a signal intersection were used in the design of this project. When the car gets close to the signal intersection, the infrared sensor sends a signal to the controller stationed at the signal post. Through this method, the controller uses the Zigbee RF transmitter to send the number of seconds needed to turn on the GREEN indication. The controller considers the time length while deciding whether to turn off the engine, based on the information received. During the time period set by the controller, all other signals will display as red. In the same way, it is possible to communicate with all cars in both directions on the signaling time length that allows them to turn off their engines, which helps save fuel and reduces pollution.

FUNCTIONAL DESCRIPTION

It is in this chapter that the project's functional description is laid out. This chapter provides a circuit description for each component of the project, which helps with comprehension. The next chapter contains the project's comprehensive block and circuit diagram.

Vehicle sensing circuit designed with LM 567 IC

Starting with section, the project work begins to function or operate. This device notifies the controller that the vehicle has been detected, which in turn allows the controller to broadcast the time length via Zigbee. If an input signal is inside the pass band, the LM567 IC, a general-purpose tone decoder, will supply a saturated transistor switch to ground. A voltage- controlled oscillator establishes the decoder's center frequency and drives two-phase detectors, the Q and I detectors, in the circuit. The center frequency, bandwidth, and output delay may be individually adjusted using external components. The 567-tone decoder IC's inbuilt VCO means that the frequency it generates is dependent on the values of R and C attached to its 5 and 6 pins, respectively. The timing resistor (RT) is located on the fifth pin, while the timing capacitor (CT) is on the sixth pin. By setting up the RC network at the IC, the VCO (Voltage Controlled Oscillator) and the Q-phase detector will produce a certain frequency that will be output from the 5th pin of the tone decoder IC. This frequency is inversely proportional to the values of R and C. When comparing the produced and received frequencies, the I-phase detector is used for decoding. The formula may be used to determine the frequency produced by the tone decoder IC:

Two microcontroller units are crucial to the functioning of the system that is detailed below. The 89C51 is the central processing unit (CPU), and the primary software is loaded into its 4 Kb of memory. Zigbee wireless technology is used to communicate the data obtained from this module to the other controller. As a result, microcontrollers are finding more and more applications in communication systems. Therefore, having a solid grasp of systems based on microcontrollers is crucial. These days, no digital communication system would be complete without microcontrollers. The performance, operational, and functional requirements have unquestionably been enhanced by dedicated systems that use microcontrollers. Micro controller devices' computation and networking capabilities caused and continue to cause architectural changes in control and instrumentation systems. The microcontroller is only a tool for data processing and transmission. When used to create a product that has practical industrial or societal applications, knowledge of microcontrollers is both meaningful and satisfying. Topics like these are directly applicable to the automation and development of products in the industrial sector. An integral part of any digital communication system, encoding and decoding methods are implemented in this project work using microcontrollers. Micro-controllers execute a single program and are hence task-specific. In most cases, the program's storage in ROM (read-only memory) remains unchanged. If the function is changed or there are software issues, the current program has to be removed from the chip and the updated program may be loaded saturated transistor switch to ground. A voltage- controlled oscillator establishes the decoder's center frequency and drives two-phase detectors, the Q and I detectors, in the circuit. The center

frequency, bandwidth, and output delay may be individually adjusted using external components. The 567-tone decoder IC's inbuilt VCO means that the frequency it generates is dependent on the values of R and C attached to its 5 and 6 pins, respectively.

DC Motor

DC motors are tiny, powerful, cheap, and utilized extensively. Managing them is a breeze. Two signals are all that's needed to power a single DC motor. Because they are not polarized, you may switch the voltage on and off without worrying about damaging the motor. The leads of a DC motor are +ve and -ve. When hooked up to a direct current (DC) power supply, the motor turns in a clockwise manner; switching the polarity causes the motor to turn counterclockwise.

Rotational speed, abbreviated as rpm, is the upper limit for DC motors. A no-load RPM and a loaded RPM are also available. When you're moving a heavy load, the rpm goes down, and vice versa when the weight goes up. Ratings for voltage and current are additional features of direct current motors. You can see the motor's specs utilized in the project in the table below.

Operating Voltage	12V DC
Operating Current	150 milli Amps
Speed	30 RPM

DC Motor Specifications

Media Access Control (MAC) layer

The IEEE802.15.4 MAC media access control layer is designed to function with a high number of devices and allows the use of many topologies without adding complexity.

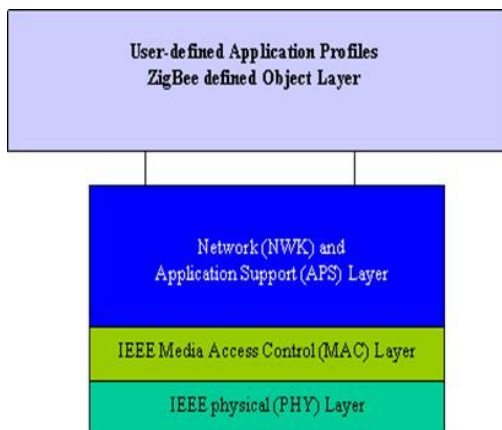

DESCRIPTION ABOUT MICROCONTROLLERS

A microcontroller is a small, integrated circuit that includes a powerful central processing unit (CPU), memory, a number of input/output (I/O) interfaces (e.g., serial and parallel ports), an interrupt controller, and data collection interfaces (e.g., digital to analog and analog to digital converters) all on a single silicon chip. If a microprocessor is used in the development of a system, the designer will need to use external memory, which includes RAM, ROM, EPROM, and peripherals. However, a single chip provides all of these capabilities to the controller. The size and cost of the PCB may be reduced by the development of a micro controller. In contrast to microprocessors, microcontrollers often work with bits rather than bytes, which is more appropriate for real-world applications.

NECESSITY OF MICROCONTROLLERS

With the advent of microprocessors, programmable devices were born, and intelligent machinery found several uses. Applications that do not need a lot of data and program memory usually wind up being expensive. To ensure that the microprocessor system could handle the data and programs, it was equipped with enough RAM and ROM to handle the majority of applications. It was also necessary to satisfy the peripheral control equipment. Consequently, the design made extensive use of all-peripheral chips. The somewhat high price tag is a result of these supplementary accessories.[7]

PIN DIAGRAM

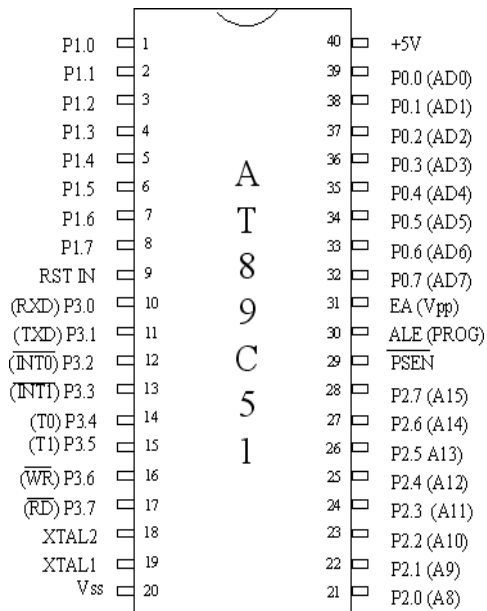

PIN DIAGRAM OF 89C51 IC

FUNCTIONAL BLOCK DIAGRAM OF MICROCONTROLLER

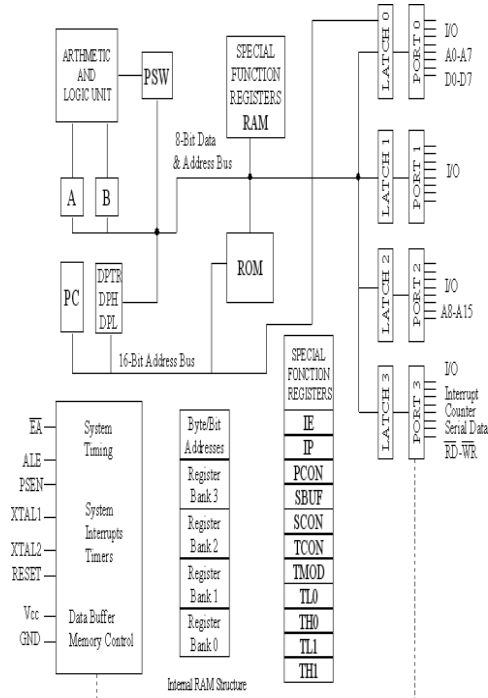

Functional block diagram of micro controller

DESCRIPTION ABOUT LCD INTERFACING

An LCD panel serves as the display section's interface, communicating with the microcontroller via the panel's output connector. There are two rows of sixteen characters apiece in this panel. You may see numbers, characters, and images on these panels. There is a user and two byte-wide registers within the display: one for instructions (RS=0) and one for the characters to be shown (RS=1). A dot matrix may be used to create a programmable RAM region, often known as the character RAM, which can be used to construct any character that is required. Bytes 80 of the hexadecimal instruction will indicate that display RAM address 00h is selected, thereby differentiating these two data sections. 89C51 microcontrollers are used to build the LCD circuit. Eight are data pins and three are control pins in the sixteen-pin LCD. The 32-input-output (I/O) lines on the microcontroller used in this project are connected to the ten-output (D0–D7) data pins on the LCD panel, which are known as 8-bit data pins, and enable the panel to receive data from the microcontroller. The connection between the microcontroller and the display unit is seen in the diagram below.[8]

Auto Control Of Vehicle At Traffic Signaling Post

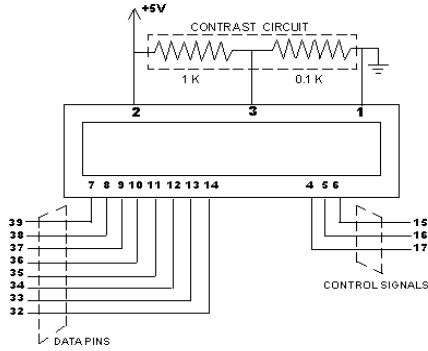

Interfacing the display unit to the microcontroller:

The following diagram shows that pins 4–6 are control signal pins used for selecting the register bank, reading and writing, and turning the device on or off, respectively. Pins 7–14 are data pins used for character selection. The display's contrast may be tweaked by modifying the voltage at pin 3.[9] In order to show a certain character, the data pins must have its corresponding logic sequence and the write signal (Pin-6) must be enabled. Based on the software that is stored into it, the microcontroller does all of these tasks. At the receiving end, the data pins are programmed by the microcontroller using the logic sequence that is acquired from the decoder output.

Pin	Symbol	I/O	Description
1	Vss	--	Ground
2	Vcc	--	+5V Power Supply
3	VEE	--	Power supply to Control Contrast
4	RS	I	RS = 0 to select command register, RS=1 to select data register
5	R/W	I	R/W =0 for write, R/W=1 for read
6	E	I/O	Enable
7	DB0	I/O	The 8-bit data bus
8	DB1	I/O	The 8-bit data bus
9	DB2	I/O	The 8-bit data bus
10	DB3	I/O	The 8-bit data bus
11	DB4	I/O	The 8-bit data bus
12	DB5	I/O	The 8-bit data bus
13	DB6	I/O	The 8-bit data bus
14	DB7	I/O	The 8-bit data bus

Thin- Film Transistor LCD Displays Introduction and Operation

By 1968, RCA Laboratories had created the first LCD, or liquid crystal display. From watches to computers to projection TVs, LCDs have been integrated into almost every digital device since then. In this way, LCDs may be thought of as a light "valve" that can either let light through or block it. An electric field is used to modify the chemical characteristics of each Liquid Crystal Cell (LCC) in the display, causing a change in the light absorption qualities of a pixel. The light source, which may be an LED or a regular fluorescent bulb, is often situated right behind the LCD.[10] The light beam will first be directed from the source and then evenly polarized by a light polarizer before being applied to the liquid crystal (LC) matrix. The LC matrix will then decide whether this pixel should be "on" or "off" when the light beam passes through. "On" pixels cause electrical activation of the liquid crystal cell, which in turn causes the liquid's molecules to align in a certain orientation. The light will be able to pass through unaltered because of this. The molecules in the liquid disperse when the pixel is "off," which means the electric field is not applied to the liquid.

Schematic

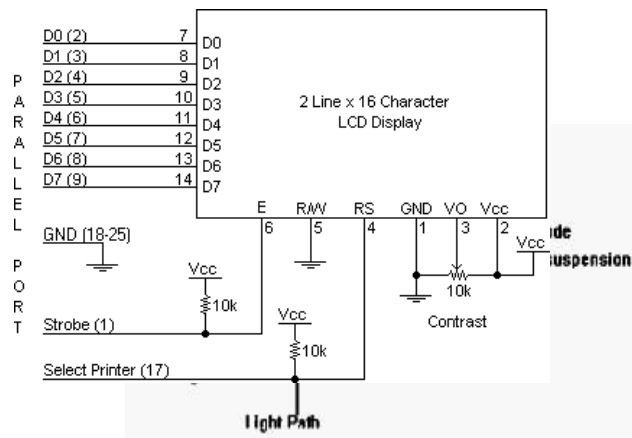

Circuit Description

This is the very basic schematic, as seen above. You may access the LCD panel's Register Select and Enable functions via the Control Port. An open collector/open drain output is the Control Port. Some Parallel Ports do not have internal pull-up resistors, while the vast majority do. So, the circuit is more versatile and may be used with a broader variety of computers by using two 10K external pull up resistors. This is because certain computers may not have internal pull up resistors. Turning the Data bus backwards is not something we attempt. As a result, we put the LCD screen into write mode by hard wiring its R/W signal. On the data lines, this will not lead to any bus conflicts. So, we can't know whether the LCD has received and processed the final command since we can't read its internal Busy Flag. Our software is able to address this difficulty by using known delays. You may adjust

the LCD panel's contrast with the 10k potentiometer. Not much going on here. The power supply is absent from all of the samples. You have two options options: either utilize the onboard +5 regulator or a bench power supply that is set to 5v. Be sure to have a few of de-coupling capacitors on hand in case you encounter any issues with the circuit's functionality. You may get 2 line x 16 character LCD modules from several different vendors; they should all work with the HD44780. A Power tip PC-1602F and an ancient Philips LTN211F-10, taken from a poker machine, were the ones I used to test this circuit. You can see the device pin numbers in the diagram over there on the right. From the front, pin 14 is on the left and pin 1 is on the right.[11]

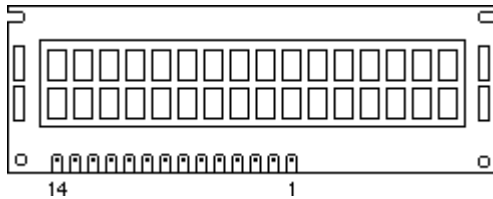

RELAYS AND THEIR APPLICATIONS

One of the first electrical devices used by humans, the electromagnetic relay had a useful application in telegraphy as early as 1850. One of the most simple, efficient, and reliable components is the contemporary relay, when used correctly. It often outperforms comparable solid-state complex relays in terms of dependability while being more cost-effective. Samuel Morse initially used the word "relay" to describe an innovation he produced in 1836. In order to facilitate the "relay" of signals, Morse devised a "Telegraph Amplifying Electromagnetic Device" that allowed a tiny current to run through a coil to activate a big current in another circuit. When the main circuit meets a set of criteria, a relay may open or shut an auxiliary circuit. A relay's primary function is to allow a weaker current to activate a much greater current; in other words, it's like an electric magnifier. Additionally, it completely isolates the controlled circuit from the controlling circuit electrically. Many industries rely on relays. When it came to issues with automated and remote control, railroads, pipelines, and heavy-duty signaling operations depended for a long time. Relays are used by the majority of our roadway traffic control signals. As a means of circuit selection and switching, relays are essential to telegraph, telemetry, and telephone systems. Relays are widely used in industrial operations for both fully automated and semi-automatic control procedures. You can count and perform mathematical calculations using relays in a computer circuit. To sum up, relays have many applications in the field of electrical and electronics engineering.

RELAY CHARACTERISTICS

Keil Software

The 8051 Microcontroller Architecture development tools from Keil are useful for programmers at all levels, from experienced applications engineers to students just starting out in the field of embedded software. For all 8051 derivatives, the industry-standard tools including Keil C Compilers, Debuggers, Macro Assemblers, Real-time Kernels, Single-board Computers, and Emulators are available to help you finish projects on time.

Simulation

With the μ Vision Simulator, you may use your own computer to debug programs with the help of simulation drivers made available by Keil and other developers. An excellent simulation environment, such as μ Vision, mimics the whole target system, including startup code, on-chip peripherals, external signals, I/O, interrupts, and more than just the microcontroller's instruction set.

ADVANTAGES

1. Reducing power consumption and space is one of the benefits of an embedded system.
2. All microcontroller-based embedded systems include ROM, input/output (I/O), and COM ports into a single chip, and they all have low power consumption.

CHIP BURNING PROCESS

The CA51 Compiler Kit is compatible with the 8051 micro controller family of products from many different manufacturers. These include Analog Devices, Atmel, Cypress Semiconductor, Dallas Semiconductor, Goal, Hynix, Infineon, Intel, OKI, Philips, Silica Labs, SMSC, ST Microelectronics, Synopsis, TDK, Temic, Texas Instruments, and Winbond, among many others.

HARDWARE DETAILS

This project's essential components, including the integrated circuits (ICs), were purchased at the Hyderabad Electronics Market. The ICs' data sheets and other specifications may be accessed online. Websites where the data sheets may be found are as follows.

The following are the components used in the project work:

1. Atmel 89C51 Micro Controller IC
2. LM 567 Tone Decoder Chip
3. Zigbee modules
4. Voltage Regulator IC (7805)
5. BC 547 NPN Transistor
6. Relay

The project work needed printed circuit boards, which were manufactured by SUN RISE CIRCUITS at Hyderabad's Kushaiguda Industrial Estate. The production of industrial-grade printed circuit boards is a specialty of Kushaiguda Industrial Estate.

RESULTS

Automated vehicle engine control at traffic signaling posts usually makes use of sensors to identify incoming cars and modify engine settings appropriately. The device may detect when a vehicle is getting close to a signaling post and briefly turn off or lower the engine's idle speed to cut down on fuel usage and pollutants. Restarting the engine or increasing the idle speed will allow for smooth acceleration whenever the light turns green or when the vehicle is ready to go. The installation of such a system often leads to better gas mileage, less pollution, and less congestion at junctions.

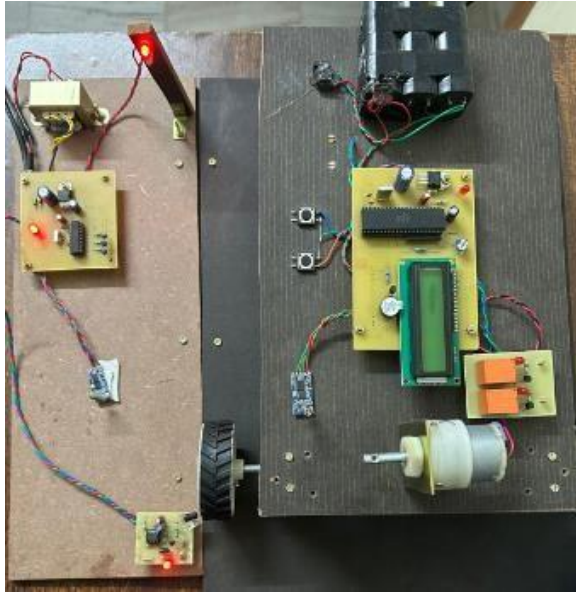

Output

CONCLUSION

The project work was completed with success; a prototype module was built for demonstration purposes, and the results were good. We talked with a small group of specialists from several Hyderabad-based firms that have extensive understanding in the relevant domains to aid in the design and development of this prototype module. Just so you know, this traffic signaling system is only meant for one way traffic. With few adjustments, the signaling post can accommodate cars traveling in all four directions using the same mechanism. Everything is running well with the Zigbee modules that were bought for the project. While on the trail, we checked the transmitter's range and discovered that can send data up to 60 feet away.

REFERENCES

The following are the references made during the development of this project work.

A design model for Automatic vehicle speed Control, International Journal for Computer Applications, volume-35, No.9, December 2011.

[2]. Design and Prototype of an In-Vehicle Road Sign Delivery System using RFID, 2012 12th International Conference on ITS Telecommunications.

[3]. Design of RF based Speed control system for vehicles, International Journal of Advanced Research in Computer and Communication Engineering Vol. 1, Issue 8, October 2012.

[4]. Vehicle Speed Control using R.F. Technology, 5704017, June 2006, SRM institute of Science and Technology

[5]. Jerry Banks, David Hanny, Manuel Panchano, Les G. Thompson – RFID Applied – 2007, John Wiley and sons.

[6]. “Follmer, W. C.” (1974). “Electronic Speed Control”, SAE Tech. Paper # 740022.

[7]. LPC2141/42/44/46/48 Data Sheet, Rev 0.1, 7 September 2005

[8]. <http://youthworldcom.blogspot.in/p/automatic-vehicle-over-speed.html>

[9]. <http://www.engineersgarage.com/electronic-circuits/dc-motor-control-circuit-wireless-rf>

[10]. Gangadhar, S.; R N shetty Inst. Of Technol, An intelligent road traffic control system, *IEEE* conference publication Kharagpur (2010)

[11]Khairnar Mayank - "Idealing of Vehicle at Traffic Signals leads to Fuel Wastage and Emission". 2015

[12]K. Vidhya - "Density based Traffic Signal System", 2014

[13]Behrang Asadi - "Predictive use of Traffic Signal State for Fuel Saving, 2009

[Type here]