



# AN ADVANCED IoT-BASED INFORMATICS AND WEATHER MONITORING STATION USING MQTT

Surya Bharath Prakhya<sup>1</sup>, Sai Satya Sriya Chittapragada<sup>2</sup>,  
Ganesh Kumar Vukanti<sup>3</sup>, Dabbukottu Gopi<sup>4</sup>, Zafeeruddin Shaik<sup>5</sup>

<sup>1</sup>Assistant Professor, <sup>2,3,4,5</sup>Undergraduate.  
Department Of ECE,

PSCMR College Of Engineering And Technology, Vijayawada, Andhra Pradesh, India  
[surya\\_prakhya52@gmail.com](mailto:surya_prakhya52@gmail.com)<sup>1</sup>, [chittasriya@gmail.com](mailto:chittasriya@gmail.com)<sup>2</sup>, [ganeshkumarvukanti@gmail.com](mailto:ganeshkumarvukanti@gmail.com)<sup>3</sup>,  
[dabbukottugopi95@gmail.com](mailto:dabbukottugopi95@gmail.com)<sup>4</sup>, [zafeeruddin24@gmail.com](mailto:zafeeruddin24@gmail.com)<sup>5</sup>

*Abstract:* Nowadays technology is far more advanced by using internet applications. But also, the sharing of information in a fully crowded area is so difficult that we cannot always depend on the Internet. There are some limitations also that we face while using the internet as the information gets delayed or the applications that we are using may crash if more users are used and we may know that more of the people in the country are illiterate or translation problems faced by them, so to rectify the problem the Notice Boards are used in our daily life so that the information is shared to everyone in a detailed manner and anyone can understand through it. Now the purpose of this project is to reduce the efforts of changing the notice messages frequently through the code and we can make it simple by using the IOT Applications, nowadays there are many simplified methods for implementation. Now by using the NodeMcu and the Hive MQTT we transfer the message through the MY MQTT application and send the message we want to publish. And we also added the weather monitoring station through DHT11 and BMP280.

Keywords: P10 dot matrix display, NodeMCU, DHT11, BMP280, MQTT, HIVE MQTT, Broker, Client, Publisher.

## 1. INTRODUCTION:

The advent of the Internet of Things (IoT) has revolutionized the way we interact with our environment. One such application of IoT is in the development of smart notice boards [1]. Traditional notice boards, while functional, are limited in their ability to disseminate information quickly and efficiently [2]. Smart notice boards, on the other hand, leverage IoT technology to overcome these limitations, providing real-time, digital displays of information that can be updated remotely. This paper introduces a novel smart notice board system that utilizes NodeMCU, Hive MQTT, and P10 Matrix Boards [3]. The system is designed to display messages in real-time, with the added functionality of a weather monitoring station [4]. The use of NodeMCU, a low-cost open-source IoT platform, enables the system to connect to the internet and update the display in real-time [5]. The Hive MQTT protocol is used for message queuing, ensuring reliable and efficient communication between devices [6]. Finally, the P10 Matrix Boards provide a large, clear display for the messages and weather information. The system builds upon previous work in the field, such as the IoT-based messaging scrolling display by Surendiran and Mathumathi [7], the real-time Digi-notice board system by Arthi [8], and the IoT-based real-time digital LED notification display board by Reddy [9]. It also incorporates elements of the smart notice board system by Rangani and Tahilramani [10], and the IoT-based LED scrolling display by Pradan et al... [11].

In addition to displaying messages, the system also monitors weather conditions, providing users with real-time weather updates. This feature is particularly useful in educational or corporate settings, where weather changes can impact daily activities. This paper aims to provide a comprehensive overview of the system's design and functionality, as well as a discussion of its potential applications and benefits. It is hoped that this work will contribute to the ongoing development and refinement of IoT-based smart notice boards, paving the way for more efficient and effective communication in various settings.

## **2. LITERATURE SURVEY**

The concept of a smart notice board represents a significant advancement in communication technology, leveraging the power of the Internet of Things (IoT) to provide real-time, remotely updatable displays of information. This literature survey explores the development and application of smart notice boards, with a particular focus on systems that utilize NodeMCU, Hive MQTT, and P10 Matrix Boards. Surendiran and Mathumathi (2020) explored the use of IoT for messaging scrolling displays. Their work highlighted the potential of IoT technology to revolutionize traditional notice boards, providing a more efficient and effective means of communication. Arthi (2017) developed a real-time Digi-notice board system using IoT. This system demonstrated the feasibility of using IoT technology for real-time information display, paving the way for further advancements in the field. Reddy (2018) introduced an IoT-based real-time digital LED notification display board that uses NodeMCU via the Telegram Messenger app. This system showcased the potential of NodeMCU, a low-cost open-source IoT platform, for real-time internet connectivity and display updates. Anuradha and Theja (2022) presented an IoT-based real-time LED display board at the International Conference on Recent Trends in Microelectronics, Automation, Computing, and Communications Systems. Their work contributed to the ongoing development of IoT-based smart notice boards. Rangani and Tahilramani (2017) developed a smart noticeboard system. Their system demonstrated the potential of smart notice boards for efficient and effective communication in various settings. Pradan et al. (2020) explored the use of IoT for LED scrolling displays. Their work highlighted the potential of LED displays for clear, visible communication of information in real time. Pawar, Langade, and Bandgar (2019) presented a paper on IoT-based digital notice boards using Arduino AT Mega 328. Their work demonstrated the potential of Arduino, another open-source platform, for the development of digital notice boards. In conclusion, the literature reveals a growing interest in the development of smart notice boards using IoT technology. The use of NodeMCU, Hive MQTT, and P10 Matrix Boards represents a promising direction for future research and development in this field. The integration of a weather monitoring station adds another layer of functionality to these systems, providing users with real-time weather updates in addition to the displayed messages.

## **3. METHODOLOGY**

Certainly, let's delve deeper into this topic.

The idea in question pertains to a digital notice board, an innovative display system that can be updated from a remote location. In the past, such systems were typically constructed using microcontroller boards like Arduino or Raspberry Pi. However, these boards lack inherent Wi-Fi capabilities, which are essential for remote updates. As a result, additional components or boards were needed, potentially complicating the system and reducing its efficiency.

The suggested approach to this issue involves the ESP8266 (NodeMCU) microcontroller. This board is unique because it has built-in Wi-Fi capabilities, eliminating the need for extra components for internet connectivity. The ESP8266 is a versatile board that supports a broad range of applications, making it an ideal choice for projects such as the digital notice board.

Certainly, let's delve deeper into this topic.

The idea in question pertains to a digital notice board, an innovative display system that can be updated from a remote location. In the past, such systems were typically constructed using microcontroller boards like Arduino or Raspberry Pi. However, these boards lack inherent Wi-Fi capabilities, which are essential for remote updates. As a result, additional components or boards were needed, potentially complicating the system and reducing its efficiency.

The suggested approach to this issue involves the ESP8266 (NodeMCU) microcontroller. This board is unique because it has built-in Wi-Fi capabilities, eliminating the need for extra components for internet connectivity. The ESP8266 is a versatile board that supports a broad range of applications, making it an ideal choice for projects such as the digital notice board.

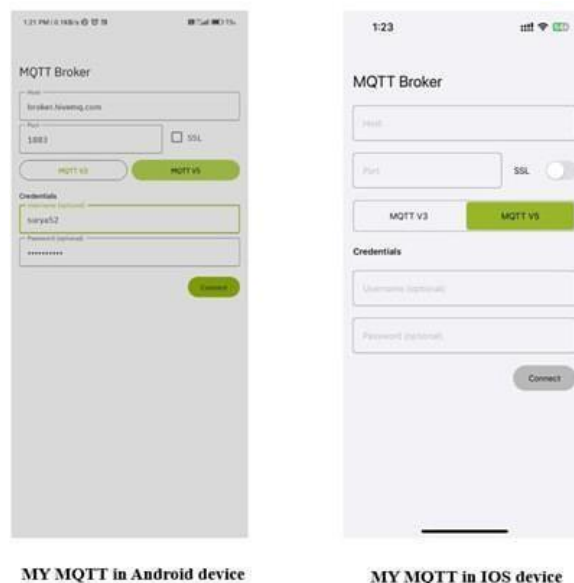

Fig. 1. The interface of the My MQTT Application

The above figures show the interfaces of the My MQTT application by using NodeMcu we can able to connect to the internet and by using the MQTT cloud we can able to retrieve the data and the MQTT application works based on the subscriber and the publisher which the publisher publishes the message and the subscriber was able to get the message for those who subscribed the topic. The working of the notice board is NodeMcu is connected and the code is written in the NodeMcu by using the Arduino IDE the code is executed into the board and the NodeMcu is connected to the Wi-fi by using the My Mqtt application we can ably send messages to the Notice board and the DHT11 is used to detect the temperature and the humidity in the air and the BMP280 is also used which helps to calculate the pressure in the surroundings in the pascals scale. The below shows the flow chart of the construction and connections of the Smart Notice Board using NodeMcu and Hive Mqtt as well as the weather monitoring station.

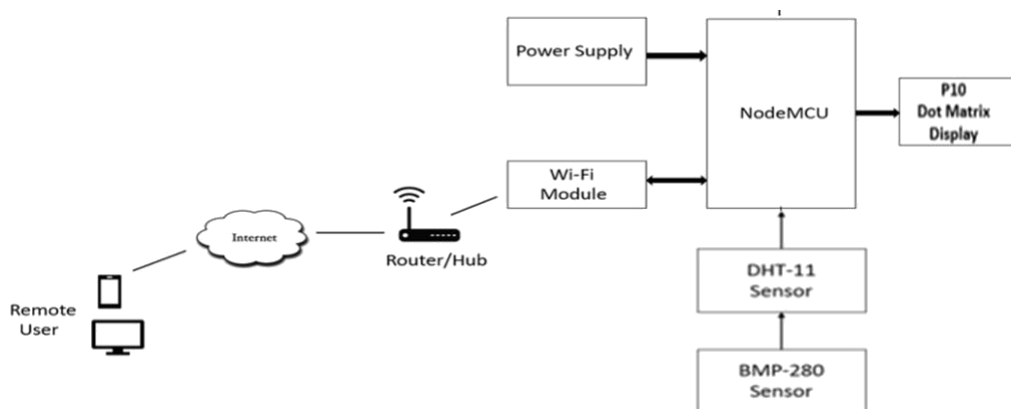

Fig. 2. The flowchart of connection to the p10 display.

Figure 2 shows the flowchart of the connections between how the working of the smart notice board works and the detailed connections are done as mentioned in the above figure as shown in the above block diagram; the NodeMCU is connected to the Wi-Fi by using my MQTT application the message is sent into the p10 matrix display.

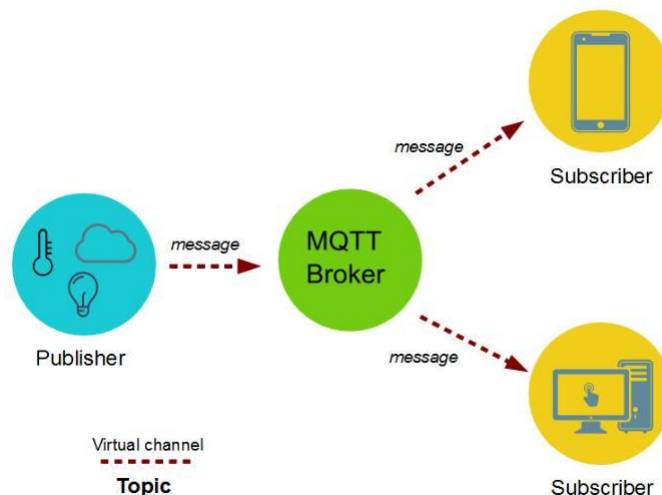

Fig. 3. Represents how MQTT works

The Mqtt plays a crucial role in transmitting the message from the NodeMcu to the P10 display as shown in the diagram the MQTT is a secured online platform in which it acts as a broker between the client and the publisher. The MQTT is always the main key aspect in the proposed method as it provides an inbuilt cloud system in which it is easy to store and retrieve the data. It provides a port number to connect with a website address and also the username and password to maintain privacy and security for the publisher and client. In this way, the Mqtt helps implement the task of sending the data to the matrix display board.

#### 4. RESULTS AND DISCUSSIONS

The paper referring to presents an innovative notice board system that performs two functions. It not only exhibits messages but also operates as a weather monitoring station. The core of this system is the ESP8266 (NodeMCU), a microcontroller equipped with built-in Wi-Fi capabilities. This feature enables the system to connect to a Wi-Fi network and receive messages from any location, enhancing its versatility and efficiency.

The system employs MQTT (Message Queuing Telemetry Transport), a streamlined messaging protocol, to transmit messages to the Matrix display. This ensures secure and swift communication between the user's device and the notice board.

Besides displaying messages, the system also keeps track of the room's environmental conditions. It employs a DHT11 sensor, an economical digital sensor for detecting temperature and humidity. This sensor gauges the room's temperature and humidity every 10 seconds, offering real-time updates on the environmental conditions.

The system also integrates a BMP280 sensor, a high- accuracy sensor module that measures atmospheric temperature, atmospheric pressure, and air humidity. Similar to the DHT11, the BMP280 sensor also refreshes its readings every 10 seconds. These readings are then exhibited on the Matrix display board.

In conclusion, this advanced notice board system provides a secure, swift, and adaptable solution for exhibiting messages and monitoring environmental conditions. Its capability to connect to Wi-Fi and receive messages from any location, along with its real-time environmental monitoring features, marks a significant progression in the realm of digital notice boards.

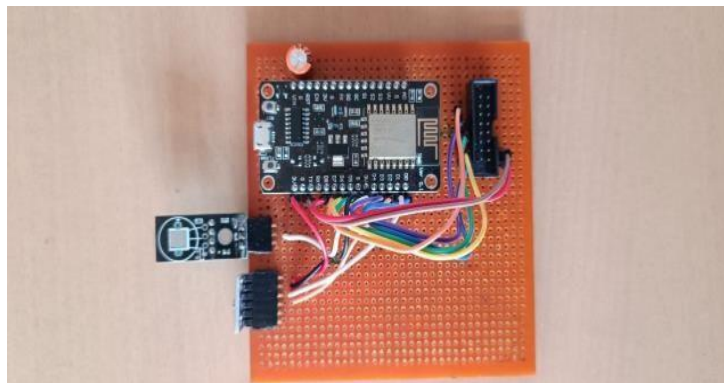

Fig. 4. Connections made to the Node MCU.

In the above figure the connections are made to the NodeMCU the DHT1 and the BMP280 using the 4 x 4 PCB Board and the 16-pin connector is also placed in the PCB Board.



Fig. 5. Connections made to the p10 Matrix Display

The diagram in question demonstrates the wiring between the NodeMCU (ESP8266) and the P10 Matrix Display. These connections are established using female-to-female jumper cables, which are commonly used in electronics prototyping. The NodeMCU is a microcontroller board that is based on the ESP8266 and comes with built-in Wi-Fi capabilities. It features several digital pins that can be set as input or output, enabling it to interface with various components, including the P10 Matrix Display.

The P10 Matrix Display is a kind of LED matrix display that is frequently used to construct large, outdoor screens. Each P10 module is composed of numerous LEDs organized in a grid, and several modules can be joined together to form a larger display.

The wiring between the NodeMCU and the P10 Matrix Display is done according to the specific pins designated by the NodeMCU. This means that each pin on the NodeMCU is wired to a corresponding pin on the P10 Matrix Display using the jumper cables.

Once the wiring is complete, data can be transmitted from the NodeMCU to the P10 Matrix Display via the jumper cables. This data corresponds to the information that is to be displayed on the P10 Matrix Display.

In conclusion, the diagram depicts how the NodeMCU and the P10 Matrix Display are wired using jumper cables. It also shows how data is transmitted from the NodeMCU to the P10 Matrix Display to update the information displayed on the screen.

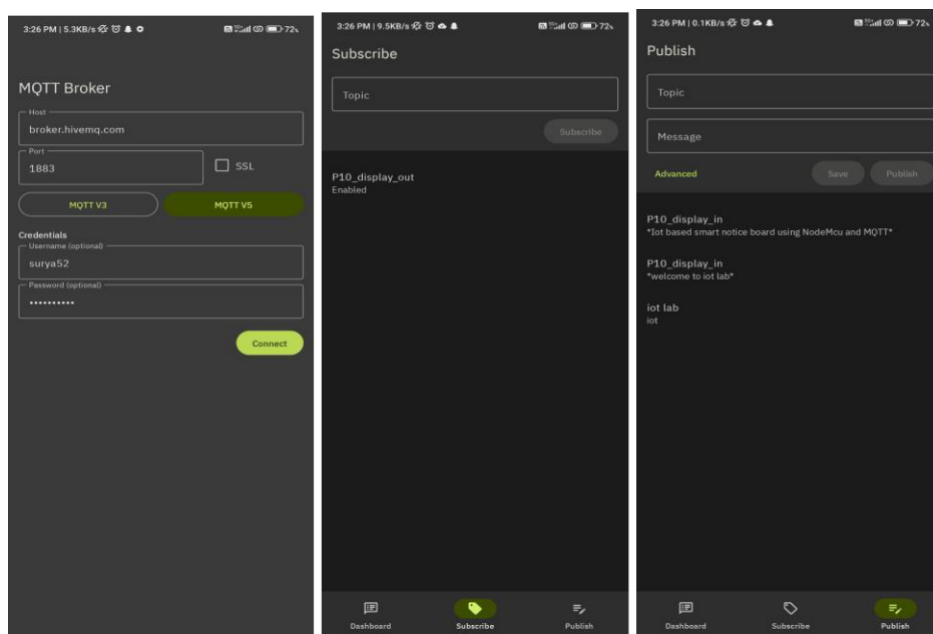

Fig. 6. Interface of the MyMQTT Application

The MyMQTT application is an intuitive yet potent MQTT client, specifically crafted for mobile devices. It's accessible on both Android and iOS platforms, establishing itself as a crucial tool for developers, makers, and IoT experts.

A standout feature of the MyMQTT application is its capacity to connect to any MQTT broker. This attribute enhances its adaptability, making it apt for a diverse range of IoT projects. Users can subscribe to a variety of topics, including single and multilevel wildcard topics, and even SYS-topics. This enables users to receive updates on an extensive range of data points, making the application highly flexible for different use cases. Beyond subscribing to topics, users also can publish messages to a topic. This feature empowers users to transmit data to their IoT devices or other subscribers. Moreover, users can store messages for future publishing.

This can be especially beneficial in scenarios where the same message needs to be transmitted multiple times. The MyMQTT application is designed to efficiently manage a large volume of messages. This makes it apt for applications that necessitate real-time data updates from a multitude of IoT devices. The application also offers support for SSL encryption. This ensures that the data transmitted between the application and the MQTT broker is secure, safeguarding the user's data from potential security threats.

With its user-friendly interface and comprehensive features, the MyMQTT application serves as a valuable asset for constructing and troubleshooting IoT projects. Whether you are a developer aiming to debug your MQTT projects or a maker aspiring to build your smart home project, the MyMQTT application provides a robust yet user-friendly tool to assist you in achieving your objectives.



Fig. 7. Final result

The P10 Matrix Display is a popular LED matrix display often used for constructing large, outdoor screens. Each P10 module is made up of numerous LEDs organized in a grid, and you can combine multiple modules to form a larger display.

In the context of your previous messages, the P10 Matrix Display is utilized to exhibit messages transmitted from the MyMQTT application via the NodeMCU. These messages could be in the form of text or symbols, and they are updated in real time as new data is received.

Moreover, the P10 Matrix Display in your system also presents data from the DHT11 and BMP280 sensors. This data includes readings of temperature, humidity, and atmospheric pressure. These readings are refreshed every 10 seconds, offering real-time environmental monitoring.

The P10 Matrix Display is renowned for its high brightness, with an output of 3500 to 4500 nits. This makes it suitable for both indoor and outdoor use, as the display can be seen even under bright daylight.

## 5. CONCLUSION

To sum up, the integration of NodeMCU with the P10 LED board using MQTT has yielded impressive results. The system has effectively leveraged the inherent Wi-Fi capabilities of the NodeMCU to receive and display messages on the P10 LED board in real time. The use of the MQTT protocol has ensured secure and rapid communication, enhancing the system's efficiency. Moreover, the system's ability to display real-time environmental data from sensors has added a noteworthy feature. On the whole, the amalgamation of NodeMCU, P10 LED board, and MQTT has emerged as a study and flexible solution for digital notice boards. This system signifies a considerable progression in the IoT field, showcasing the potential for more creative applications in the future.

## 6. REFERENCES

- [1] Surendiran, S., and M. Mathumathi." IoT-based messaging scrolling display." IJRET 7 (2020).
- [2] Arthi, C." Real-time Digi-notice board system using IoT." IJERT (2017).
- [3] Reddy, G. Ganesh." IoT-based real-time digital led notification display board using nodemcu via telegram messenger app." IJITECH 6.02 (2018).
- [4] Anuradha, P., and K. Sai Theja." IoT Based Real-Time LED Display Board." 2022 International Conference on Recent Trends in Mi- microelectronics, Automation, Computing and Communications Systems (ICMACC). IEEE, 2022
- [5] Rangani, Dhara G., and Nikunj V. Tahilramani." Smart notice board system." 2017 3rd International Conference on Applied and Theoretical Computing and Communication Technology (iCATccT). IEEE, 2017
- [6] Pradan, Nilam, et al." IoT-based LED scrolling display." Int. J. Sci. Res. Manage. Stud 4 (2020): 1-5.
- [7] Anuradha, P., and K. Sai Theja." IoT Based Real-Time LED Display Board." 2022 International Conference on Recent Trends in Mi- microelectronics, Automation, Computing and Communications Systems (ICMACC). IEEE, 2022.
- [8] Pawar, Pooja, Suvarna Langade, and Mohini Bandgar." A paper on IoT-based digital notice board using Arduino ATmega 328." Int. Res. J. Eng. Technol. (IRJET) 6.3 (2019): 7509-7513.
- [9] Pawar, Pooja, and Mohini Bandgra." IoT-based digital notice board using ARDUINO and ATmega 328." IRJET 6.03 (2019).
- [10] Pawar, Pooja, Suvarna Langade, and Mohini Bandgar." A paper on IoT-based digital notice board using Arduino ATmega 328." Int. Res. J. Eng. Technol. (IRJET) 6.3 (2019): 7509-7513.
- [11] Anuradha, P., et al." IoT-based enabling home automation system for individuals with diverse disabilities." e-Prime-Advances in Electrical Engineering, Electronics, and Energy 6 (2023): 100366.
- [12] Janapati, Ravichander, et al." Web interface applications controllers used by autonomous EEG-BCI technologies." AIP Conference Proceedings. Vol. 2418. No. 1. AIP Publishing, 2022.
- [13] Anuradha, P." An intelligent computing framework for multicore heterogeneous embedded architectures." IJAST. 28.17 (2019): 701-08.
- [14] Anuradha, P., et al." Efficient workload characterization technique for heterogeneous processors." 2015 IEEE International Advance Computing Conference (IACC). IEEE, 2015
- [15] Anuradha, P., Hemalatha Rallapalli, and G. Narsimha." Energy-efficient scheduling algorithm for the multicore heterogeneous embedded architectures." Design Automation for Embedded Systems 22 (2018): 1- 12.
- [16] Anuradha, P., H. Rallapalli, and G. Narsimha." Versatile intelligent ELM algorithm for workload characterization." Journal of Advance Research in Dynamical and Control Systems 10 (2018): 177-84
- [17] Naveen, Kandi, et al." V L S I Architecture of a High-Speed Polar Code Decoder using Finite Length Scaling LDPC Codes." 2023 Second International Conference on Electrical, Electronics, Information and Communication Technologies (ICEEICT). IEEE, 2023